

NMRV

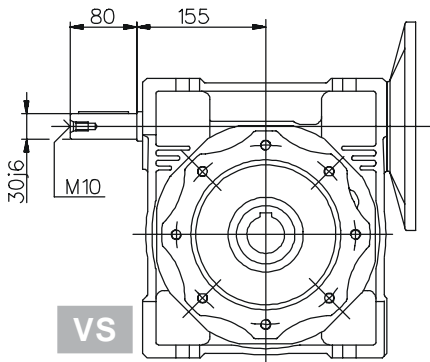

VS

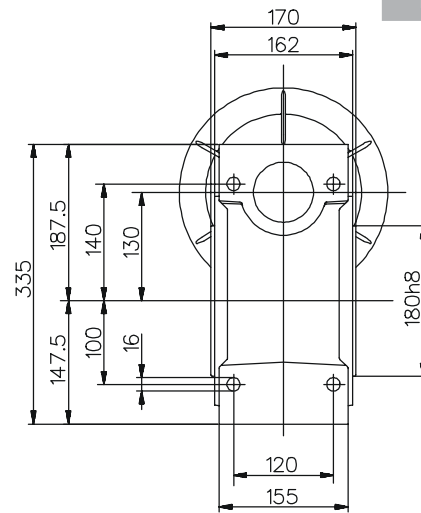
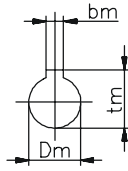
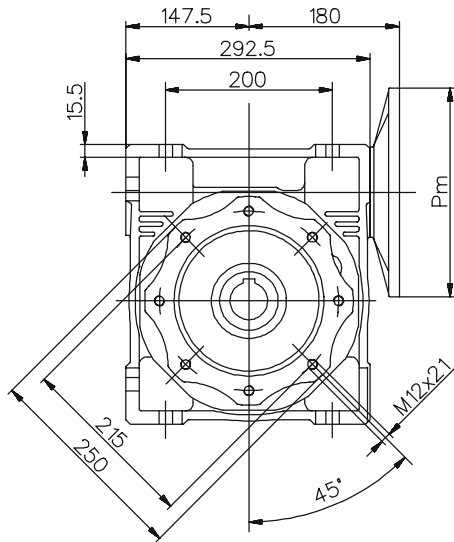
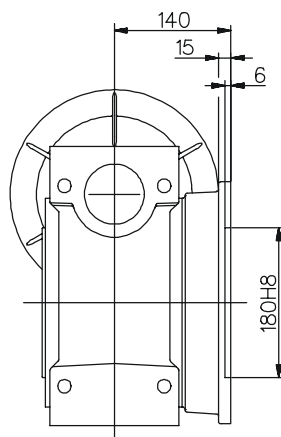
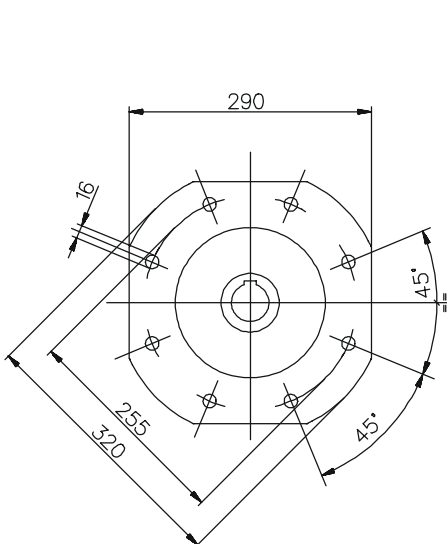
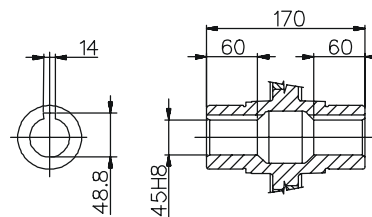
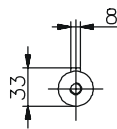

FA

- Peso senza motore ~48 kg
- Weight without motor ~48 kg
- Gewicht ohne Motor ~48 kg
- Poids sans moteur ~48 kg
- Peso sin motor ~48 kg

Per le dimensioni relative alla zona attacco motore (Pm, Dm, bm, tm) fare riferimento alla tabella di pag. 303.
 For the dimensions concerning the motor connection area (Pm, Dm, bm, tm) please refer to the table shown at page 303.
 Zu den Abmessungen des Motoranschlußflansches (Pm, Dm, bm, tm) siehe Tabelle auf Seite 303.
 Pour les dimensions concernant la zone de montage du moteur (Pm, Dm, bm, tm) lire SVP le tableau à la page 303.
 Para las magnitudes correspondientes a la zona del motor (Pm, Dm, bm, tm) consulte la tabla de la página 303.